



FE Series

Flexibility at the highest level



FETTE
COMPACTING

together

from lab to production

Better together – from lab to production

For more than 75 years, Fette Compacting has been redefining precision in industrial tablet production. As the world market leader in integrated solutions for OSD (Oral Solid Dosage) manufacturing, we deliver decisive competitive advantages. Our portfolio ranges from high-performance tablet presses to specialized Containment solutions and process equipment.

But technology is only one part of our DNA. Guided by our principle “Together – from lab to production”, we support you throughout the entire life cycle of your products: from initial formulation in the lab through technology transfer to commercial production.

That way, you find the right solution for every product and get it to market faster. With our global network of five Competence Centers in Germany, China, the USA, India, and Brazil, along with 13 subsidiaries and representatives in 50 countries, we are always right where you need us.

As your holistic process partner, we provide complete solutions. Whether pharma, nutrition, or chemical: We combine tailored consulting with deep technological know-how. The result: customized, efficient solutions for every phase of your product life cycle – and a partnership that delivers real value.

Research & Development



Production

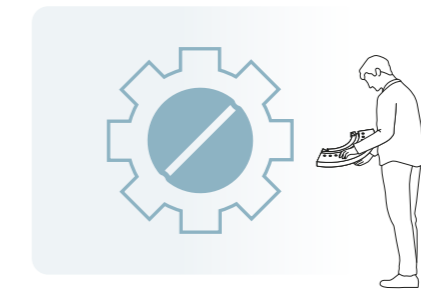

The FE Series at a Glance

With flexibility and high machine availability, the FE Series makes your production more efficient and unlocks hidden potential

The tablet presses in the FE Series deliver high performance, flexible applications, and process-reliable production. They ensure quality and efficiency in tableting while combining innovation with user-friendliness. The FE55 and the FE75 can be combined with an FE CPS for Continuous Production and enhanced with embedded Process Analytical Technology (ePAT).



HMI The Human Machine Interface enables intuitive operation thanks to intelligent software support.



FE35 The specialist for small batches – with the fastest product changeover time in its class.



FE55 The all-rounder that tackles your tableting challenges: Productive, efficient, and flexible.



FE75 The double rotary tablet press delivers peak performance for high-volume production of demanding products.

Punch stations (max.)	32	47	79
Maximum output (tablets/hour)	367,200	626,400	1,656,000
Tablet diameter (max.)	25 mm	25 mm	25 mm

Shared Strengths

The FE Series impresses with its performance and ease of operation across a wide range of production scenarios

Example FE55:
Key features of the FE Series at a glance

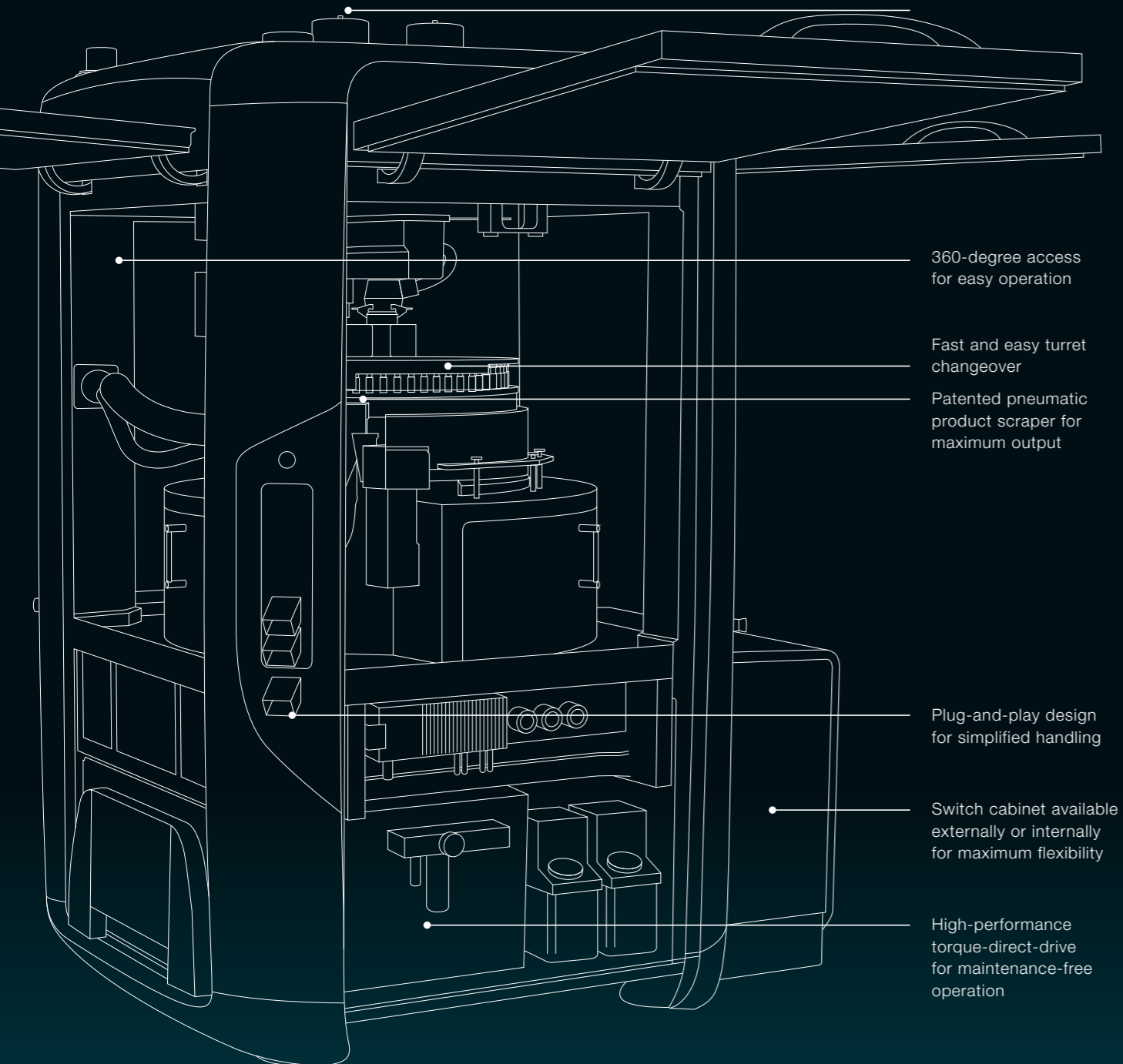

Reliable filling system – also for demanding product blends

360-degree access for easy operation

Fast and easy turret changeover

Patented pneumatic product scraper for maximum output

Plug-and-play design for simplified handling

Switch cabinet available externally or internally for maximum flexibility

High-performance torque-direct-drive for maintenance-free operation

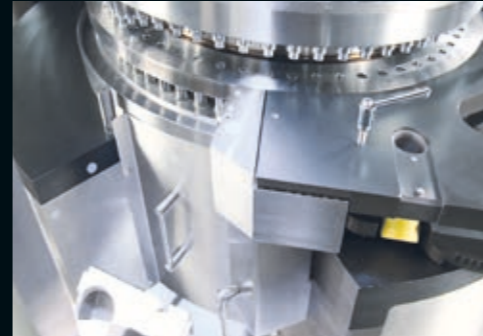

Easy and efficient

The TRI.EASY Design from Fette Compacting makes operation, maintenance, and changeover simple, safe, and fast – for example, thanks to tool-free disassembly of components. This also reduces cleaning time.

Flexible

With features such as modular compression stations and an integrated tablet discharge, the FE Series meets the highest quality and safety standards while enabling flexible adaptation to changing production needs. This gives both small and large manufacturers the agility to react quickly to evolving market requirements.

Fill-O-Matic keeps powder flowing

More than 40 years of development experience have been integrated into the unique three-chamber filling system Fill-O-Matic. The proportioning wheels enhance the flowability of the powder and ensure uniform density. Precise filling and dosing reduce product loss.

Easy to operate

The HMI operating terminal features Visual 8, the proven and optimized software from Fette Compacting. Operator comfort and safety are ensured by the intuitive and adaptable operating layout as well as the four-eyes principle for changes to critical parameters.

Connectable

The interfaces enable integration into a Manufacturing Execution System or a connection to the Internet of Things. The SmartInterface connects to the company network and provides production and process data in real time. Access via laptop, tablet, or smartphone promotes transparency, data-based production optimization and planning, as well as the ability to respond to deviations.



Four Features that Bring Your Production Up to Date

The FE Series meets all the requirements for safe and efficient tableting



Flexible filling systems

Multiple filling systems are available to choose from, ensuring an ideal solution for any given powder – including demanding product blends.

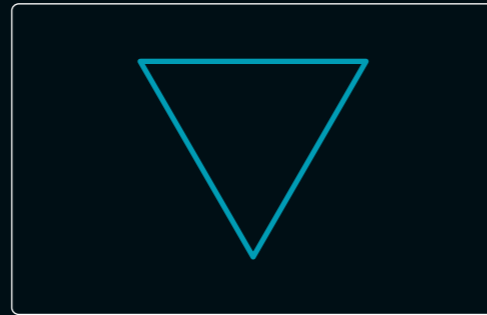

Maximum precision

The FE Series stands for highest levels of precision. Two examples: The Fill-O-Matic table can be aligned quickly and precisely with just one wheel. The automatic compression station offers finer adjustment thanks to its electric drive compared to conventional mechanical systems.



Dust-tight and Containment Option

The FE Series is dust-tight – an important factor in protecting operating personnel from active ingredient exposure. The experts at Fette Compacting advise and support you using the proprietary Containment Guard for handling active and highly active pharmaceutical ingredients. The result is a tailor-made end-to-end Containment solution.



Proven performance in Continuous Production

The FE55 combined with the FE CPS from Fette Compacting form a proven and compelling solution for Continuous Production. Customers who, after careful consulting, switched from batch production to Continuous Manufacturing now produce more efficiently and have been able to increase output in practice (despite lower nominal capacity).

FE35

Compact and Quickly Adaptable

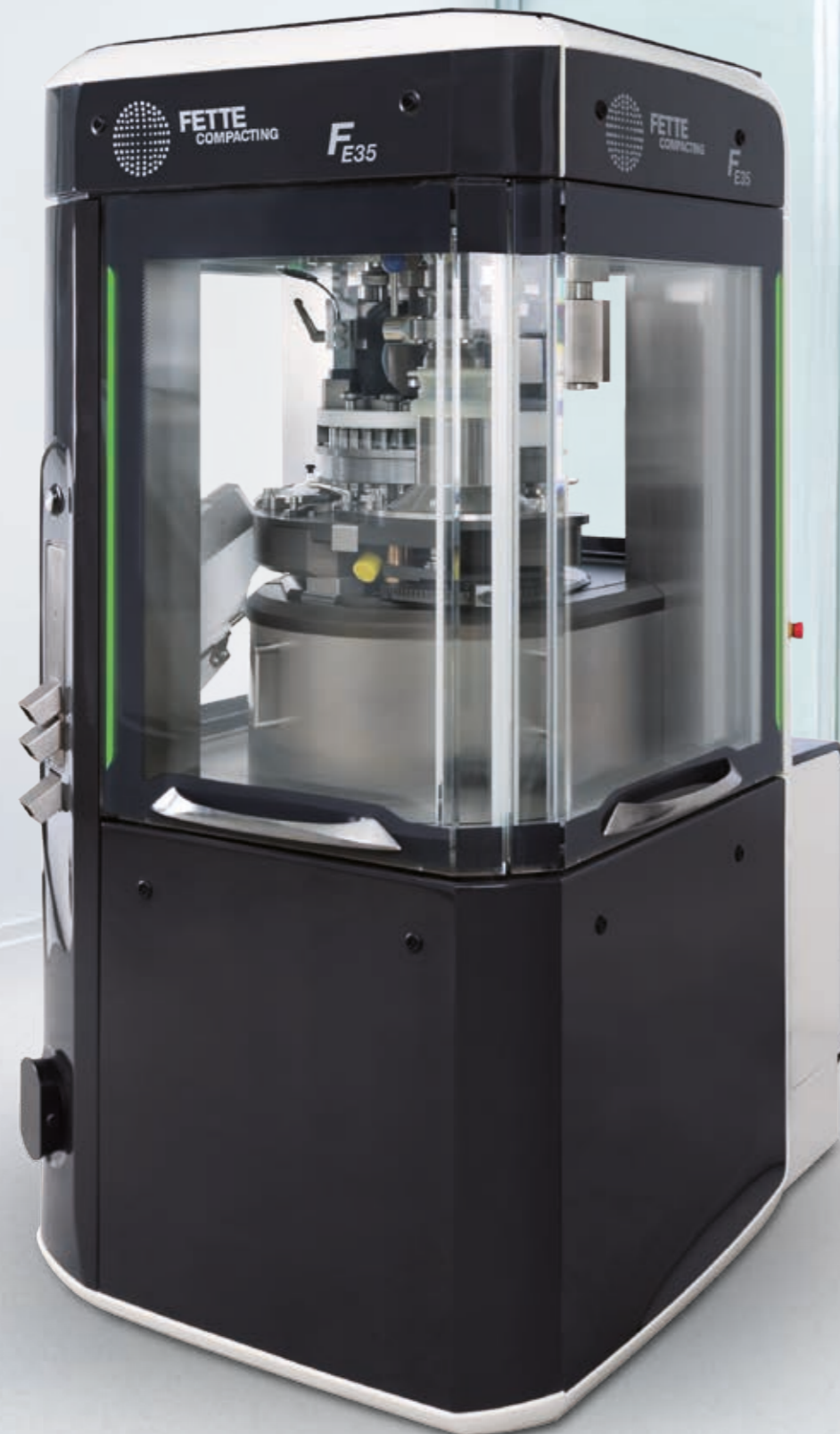

The FE35 combines the advantages of the FE Series with the shortest product changeover time in its class. Users benefit from maximum machine availability and investment security.



Tool-free working

Turret changeover requires removing only ten components – entirely without tools. The extraction system can also be removed without tools, which speeds up cleaning.



Uninterrupted production

The high-performance torque-drive runs maintenance-free and energy-efficiently. The internal tablet discharge ensures a smooth production flow.



Easy handling

Innovative compression stations: Low-friction compression rollers ensure effortless handling. Changing load cells during product changeovers is equally straightforward.

FE55

All-rounder for Maximum Flexibility



The FE55 sets benchmarks in three key factors for tableting efficiency: productivity, flexibility, and availability. As standard, it can handle more than 90 percent of all products without additional investments or complex changeovers – including bi-layer tablets.



Optimal space utilization

The tablet press geometry is fully utilized – with a maximum pitch circle relative to the footprint.



Versatile

Mono-layer, Direct Compression, and bi-layer tableting are all possible. The first-layer sample pull takes just four seconds.



Expandable

The FE55 can be combined with an FE CPS for Continuous Direct Compression. An embedded Process Analytical Technology (ePAT) inspects every tablet in real time.

FE75

Efficient Double Rotary Tablet Press for Maximum Output



The FE75 delivers peak performance for high-volume production of up to 1,656,000 tablets per hour. Key advantages include the torque-drive and innovative turret solutions.



Unique

The only double rotary tablet press of this size: Just two square meters of footprint with up to 115 punch stations.



Versatile

Mono-layer, Direct Compression, and bi-layer tableting are all possible. The first-layer sampling in just four seconds.



Adaptable for Continuous Production and ePAT

Can be adapted for Continuous Direct Compression with the FE CPS as well as embedded Process Analytical Technology (ePAT). The ePAT sensors can be retrofitted for both batch and Continuous Manufacturing, enabling continuous real-time quality monitoring.

Technical Data

FE35

The FE Series can be configured to suit your needs. We are happy to advise you on selecting the right punches, segments, and dies to achieve the optimal configuration.



Technical specifications								
Pitch circle diameter	mm	325	325	325	325	325	325	325
Compression force pre- and main compression 1*	kN	0–80	0–80	0–80	0–80	0–80	0–80	0–80
Turret rotation speed 2**	min ⁻¹	5–120	5–120	5–120	5–120	5–120	5–120	5–120
Dimensions L × W × H	mm	1,026 × 1,042 × 2,043 without integrated switch cabinet 1,336 × 1,042 × 2,043 with integrated switch cabinet						
Weight		Tablet press approx. 2,800–3,000 kg, operating terminal 100 kg, switch cabinet 350 kg						
Electrical supply parameters		Operating voltage 400–480 V, 50/60 Hz, power consumption 14 kW						

Turret specifications								
Segments (S)/ Dies (D)		S	S	S	S	D	D	D
Number of punch stations		51	33	27	24	35	28	23
Punch type		FS12®	FS19® EU19 TSM19	EU1* TSM1*	EU1*-441	FS19® EU19 TSM19 BB	FS19® EU19 TSM19 B	EU1* EU1*-441 TSM1* D
Tablet output units/h	min.	45,900	29,700	24,300	21,600	31,500	25,200	20,700
	max.	367,200	237,600	145,800	129,600	252,000	201,600	124,200
Max. compression force 1***	kN	34	80	80	80	80	80	80
Max. compression force 2***	kN	34	80	80	80	80	80	80
Max. tablet diameter	mm	11	18	25	25	13	18	25
Max. filling depth****	mm	20	20	20	20	18	18	18
Recommended turret rotation speed	min.	min ⁻¹	15	15	15	15	15	15
	max.	min ⁻¹	120	120	90	90	120	120
Segment/die height	mm	25	25	25	25	22.225	22.225	23.8
Die diameter	mm	–	–	–	–	24	30.16	38.1
Punch shaft diameter	mm	12	19	25.35	25.35	19	19	25.35
Punch length upper/lower punch	mm	133.6	133.6 (133.35)	133.6 (133.35)	133.6	133.6 (133.35)	133.6 (133.35)	133.6 (133.35)
Upper punch insertion depth	mm	1–5	1–5	1–5	1–5	1–5	1–5	1–5

Theoretical values or technical limits: These may vary in practice depending on the product and application. Tablet thickness is a product-dependent variable and can vary significantly. * The minimum pressing force must exceed a certain value for the punch to rotate the pressure roller. The maximum pressing force depends on the installed tableting tools. ** The minimum and maximum possible rotational speed depends on the specific application. *** Limited by punch properties. **** Special filling depth available on request. Disclaimer: Some of the features described in this brochure are optional and depend on the individual machine configuration upon request.

Technical Data

FE55

The FE Series can be configured to suit your needs. We are happy to advise you on selecting the right punches, segments, and dies to achieve the optimal configuration.



Technical specifications								
Pitch circle diameter	mm	550	550	550	550	550	550	550
Compression force pre- and main compression 1*	kN	0-100	0-100	0-100	0-100	0-100	0-100	0-100
Turret rotation speed 2**	min ⁻¹	5-120	5-120	5-120	5-120	5-120	5-120	5-120
Dimensions L x W x H	mm	1,306 x 1,306 x 2,048 without integrated switch cabinet 1,306 x 1,626 x 2,048 with integrated switch cabinet						
Weight		Tablet press approx. 3,700-3,900 kg, operating terminal 100 kg, switch cabinet 350 kg						
Electrical supply parameters		Operating voltage 400-480 V, 50/60 Hz, power consumption 16 kW						

Turret specifications								
Segments (S) / Dies (D)		S	S	S	S	D	D	D
Number of punch stations		87	60	45	39	58	47	39
Punch type		FS12®	FS19® EU19 TSM19	EU1" EU1"-441 TSM1"	EU28	FS19® EU19 TSM19 BB	FS19® EU19 TSM19 B	EU1" EU1"-441 TSM1" D
Tablet output units/h	min.	78,300	54,000	40,500	-	52,200	42,300	35,100
	max.	626,400	432,000	243,000	243,000	417,600	338,400	210,600
Max. compression force 1***	kN	34	100	100	80	100	100	100
Max. compression force 2***	kN	34	100	100	80	100	100	100
Max. compression force 3***	kN	34	100	100	-	100	100	100
Max. tablet diameter	mm	11	18	25	27	13	18	25
Max. filling depth	1st layer****	mm	20	20	20	13	18	18
	2nd layer	mm	8	8	8	-	8	8
Recommended turret rotation speed	min.	min ⁻¹	15	15	15	15	15	15
	max.	min ⁻¹	120	120	90	90	120	120
Segment / die height	mm	25	25	25	25	22.225	22.225	23.8
Die diameter	mm	-	-	-	-	22	30.16	38.1
Punch shaft diameter	mm	12	19	25.35	28	19	19	25.35
Punch length upper / lower punch	mm	133.6	133.6 (133.35)	133.6 (133.35)	133.6	133.6 (133.35)	133.6 (133.35)	133.6 (133.35)
Upper punch insertion depth	mm	1-5 (8*****)	1-5 (8*****)	1-5 (8*****)	1-5 (8*****)	1-5 (8*****)	1-5 (8*****)	1-5 (8*****)

Theoretical values or technical limits: These may vary in practice depending on the product and application. Tablet thickness is a product-dependent variable and can vary significantly. * The minimum pressing force must exceed a certain value for the punch to rotate the pressure roller. The maximum pressing force depends on the installed tableting tools. ** The minimum and maximum possible rotational speed depends on the specific application. *** Limited by punch properties. **** Special filling depth available on request. ***** 2-layer-operation. Disclaimer: Some of the features described in this brochure are optional and depend on the individual machine configuration upon request.

Technical Data

FE75

The FE Series can be configured to suit your needs. We are happy to advise you on selecting the right punches, segments, and dies to achieve the optimal configuration.



Technical specifications								
Pitch circle diameter	mm	710	710	710	710	710	710	710
Compression force pre- and main compression 1*	kN	0-100	0-100	0-100	0-100	0-100	0-100	0-100
Turret rotation speed 2**	min ⁻¹	5-120	5-120	5-120	5-120	5-120	5-120	5-120
Dimensions L x W x H	mm	1,463 x 1,463 x 2,046 without integrated switch cabinet 1,463 x 1,778 x 2,046 with integrated switch cabinet						
Weight	mm	Tablet press approx. 5,300-5,500 kg, operating terminal 100 kg, switch cabinet 350 kg						
Electrical supply parameters	mm	Operating voltage 400-480 V, 50/60Hz, power consumption 16 kW						

Turret specifications								
Segments (S) / Dies (D)		S	S	S	S	D	D	D
Number of punch stations		115	75	55	55	75	63	51
Punch type		FS12®	FS19® EU19 TSM19	EU1* EU1*-441 TSM1*	EU28	FS19® EU19 TSM19 BB	FS19® EU19 B	EU1* EU1*-441 TSM1* D
Tablet output units/h	min.	207,000	135,000	99,000	-	135,000	113,400	91,800
	max.	1,656,000	1,080,000	594,000	594,000	1,080,000	907,200	550,800
Max. compression force 1***	kN	34	100	100	80	100	100	100
Max. compression force 2***	kN	34	100	100	80	100	100	100
Max. compression force 3***	kN	34	100	100	-	100	100	100
Max. compression force 4***	kN	34	100	100	-	100	100	100
Max. tablet diameter	mm	11	18	25	27	13	18	25
Max. filling depth	1st layer****	mm	20	20	20	18	18	18
	2nd layer	mm	8	8	8	-	8	8
Recommended turret rotation speed	min.	min ⁻¹	15	15	15	15	15	15
	max.	min ⁻¹	120	120	90	90	120	120
Segment / die height	mm	25	25	25	25	22.225	30.16	23.8
Die diameter	mm	-	-	-	-	22	30.16	38.1
Punch shaft diameter	mm	12	19	25.35	28	19	19	25.35
Punch length upper / lower punch	mm	133.6	133.6 (133.35)	133.6 (133.35)	-	133.35	133.6 (133.35)	133.6
Upper punch insertion depth	mm	1-5 (8*****)	1-5 (8*****)	1-5 (8*****)	1-5 (8*****)	-	-	-

Theoretical values or technical limits: These may vary in practice depending on the product and application. Tablet thickness is a product-dependent variable and can vary significantly. * The minimum pressing force must exceed a certain value for the punch to rotate the pressure roller. The maximum pressing force depends on the installed tableting tools. ** The minimum and maximum possible rotational speed depends on the specific application. *** Limited by punch properties. **** Special filling depth available on request. ***** 2-layer-operation. Disclaimer: Some of the features described in this brochure are optional and depend on the individual machine configuration upon request.

Dimensions

FE35

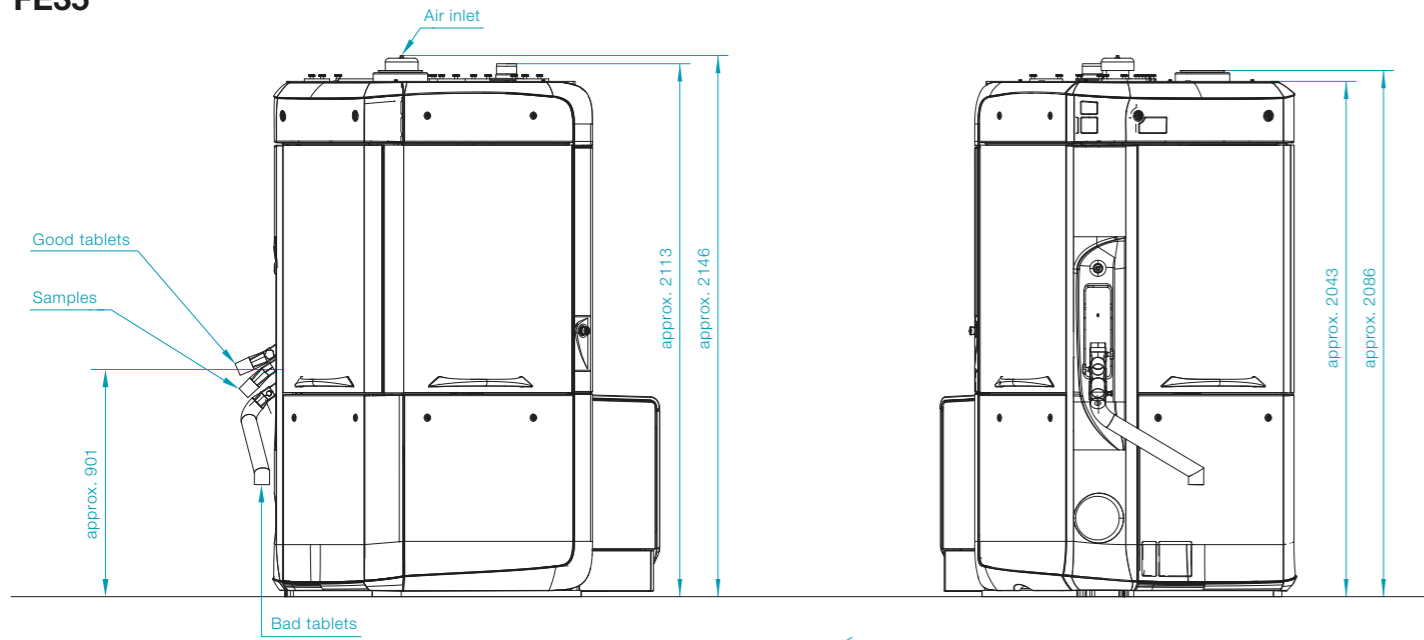

FE55

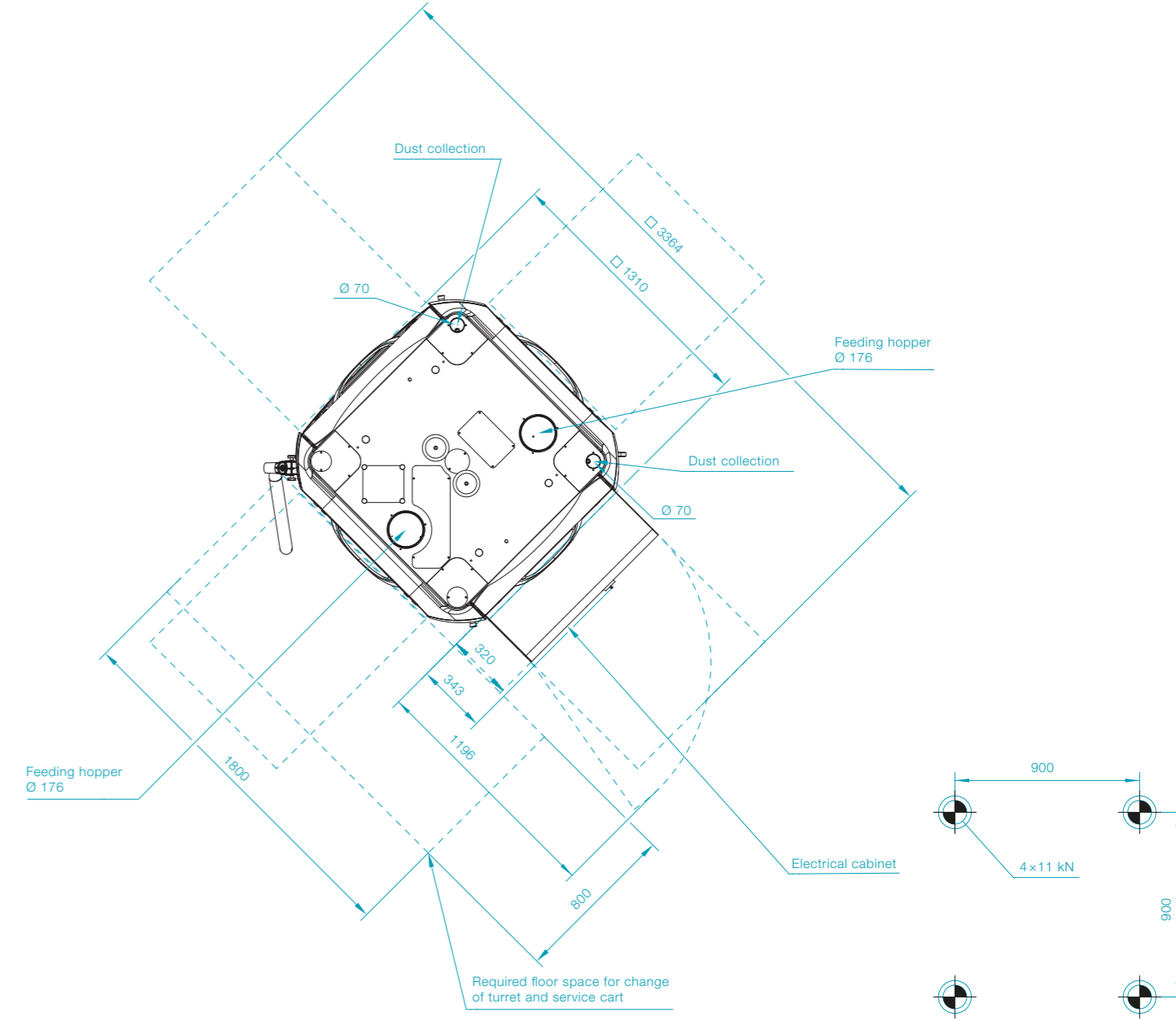
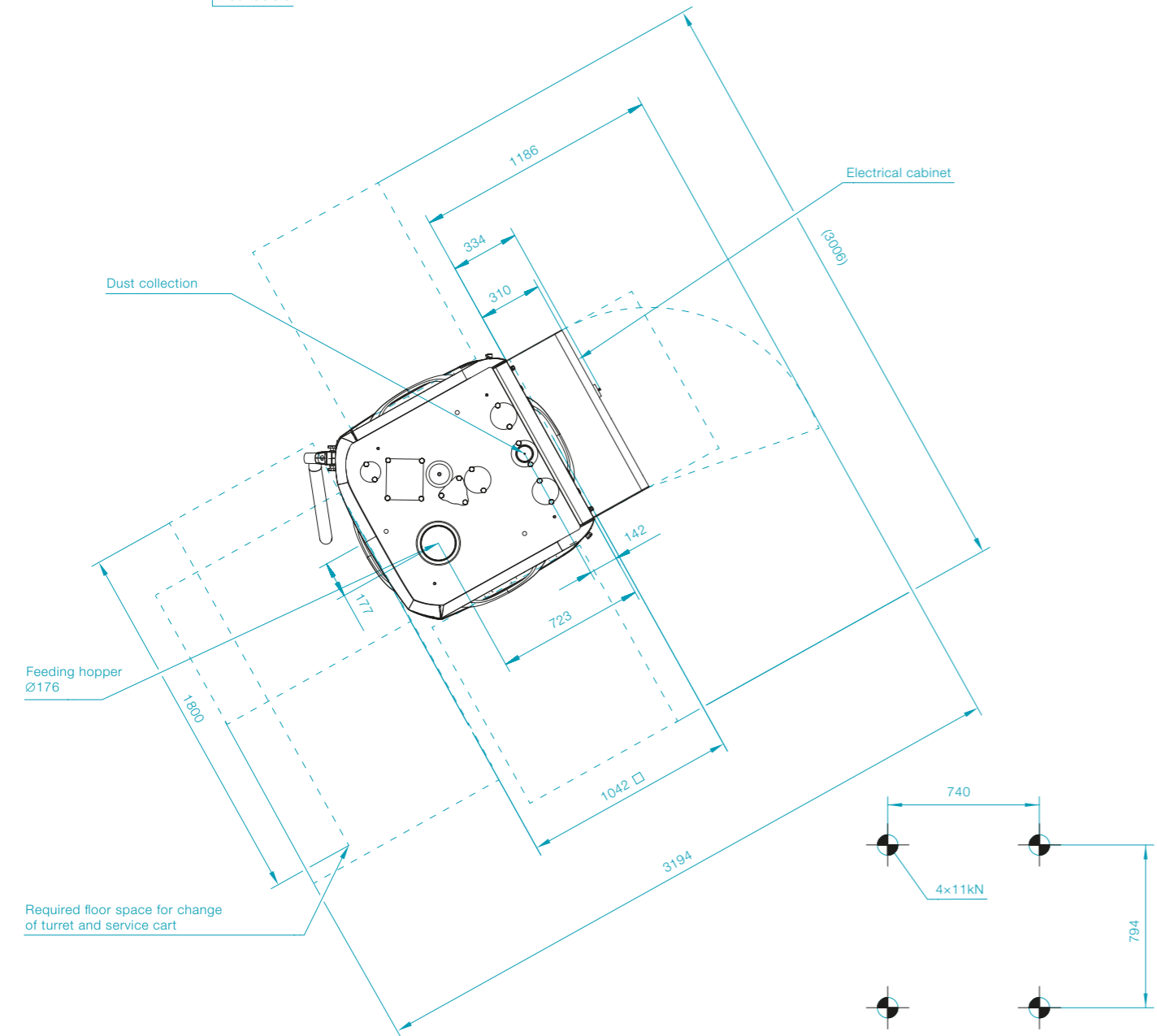
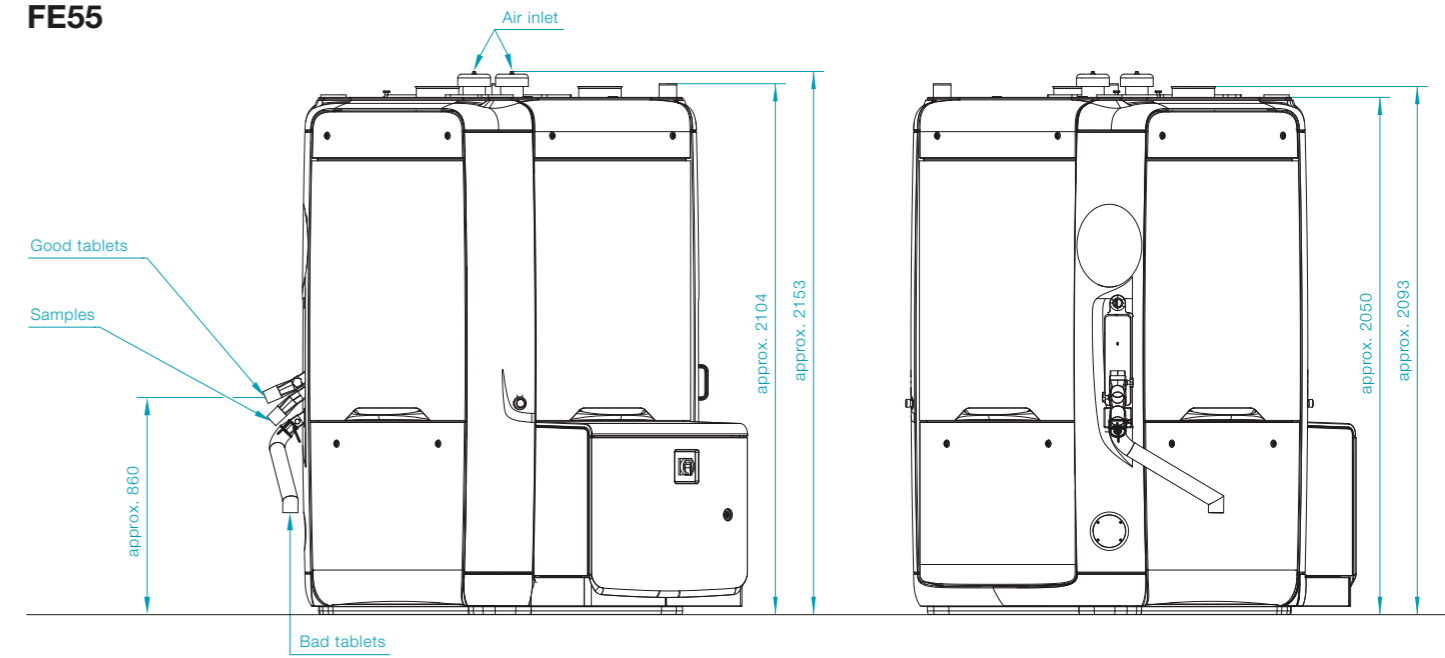

M 1:30 | All dimensions are in mm, unless otherwise specified.

Foundation loading FE35

M 1:30 | All dimensions are in mm, unless otherwise specified.

Foundation loading FE55

Dimensions

FE75

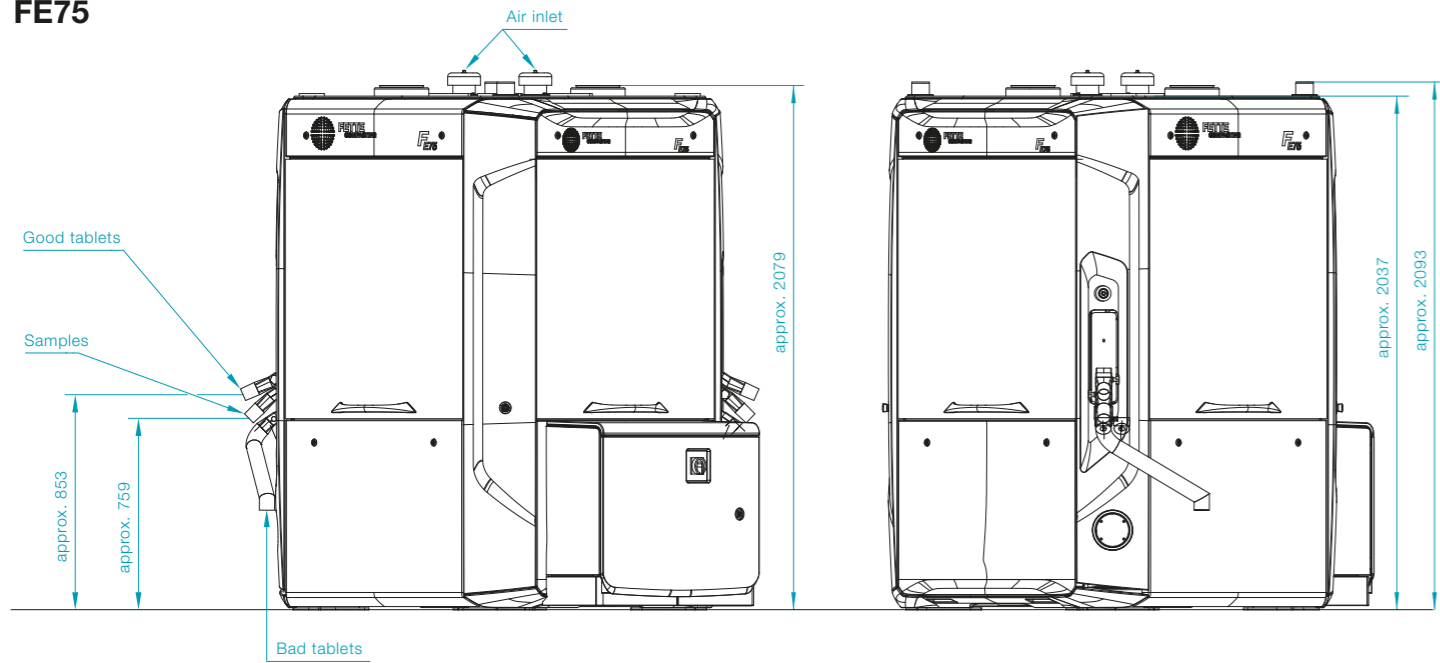

HMI Operating Terminal

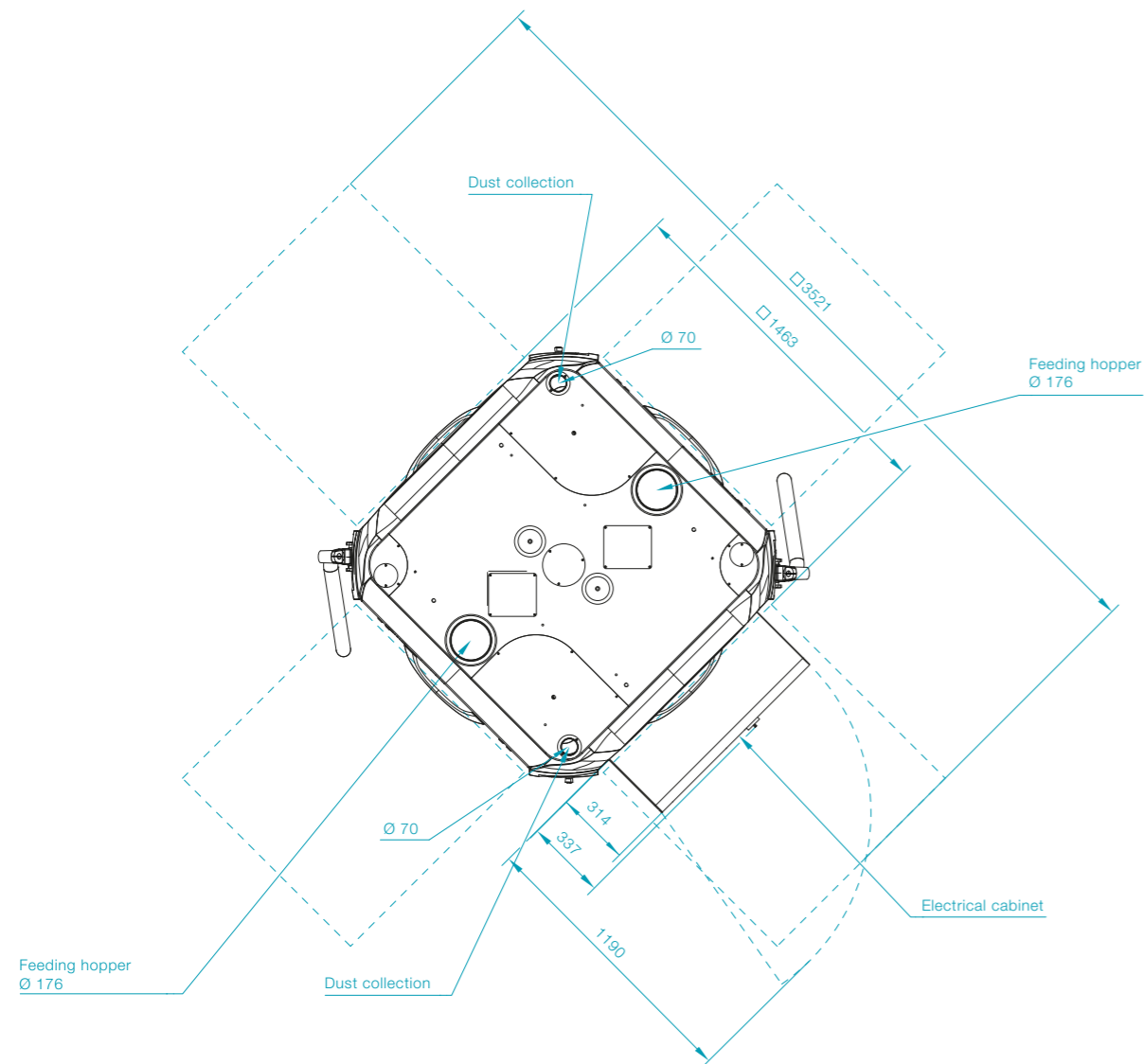
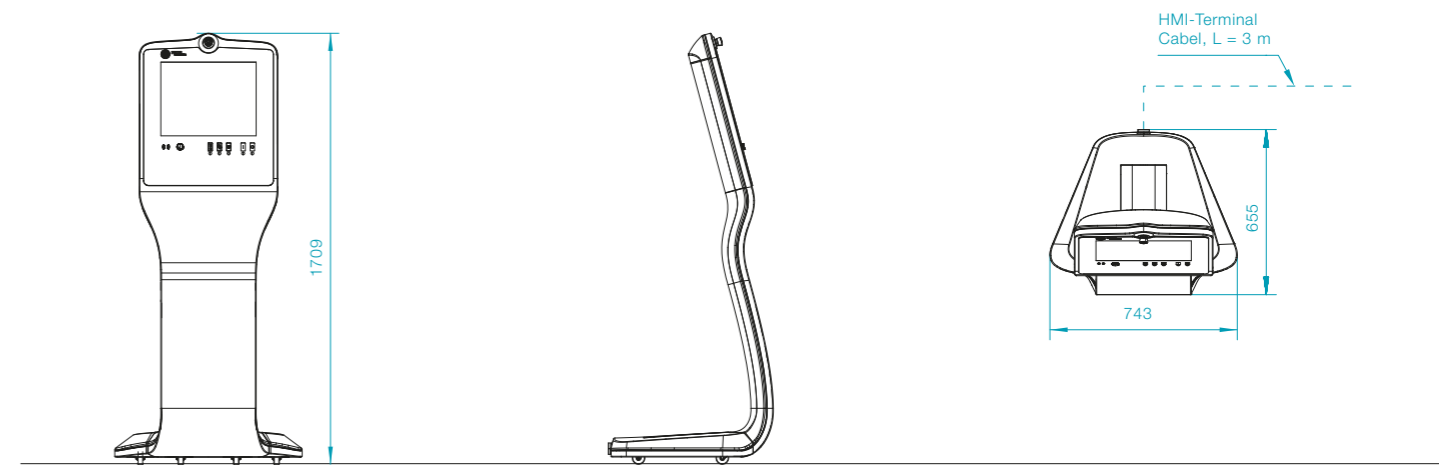

FE55

Feeding hopper		Dust extraction		
A	B	A	B	
	X		X	Mono-layer-compression
X		X	X	Direct compression
1st layer	2nd layer	X	X	Bi-layer compression

FE75

Feeding hopper		
A	B	
X	X	Mono-layer-compression
X		Direct compression
1st layer	2nd layer	Bi-layer compression

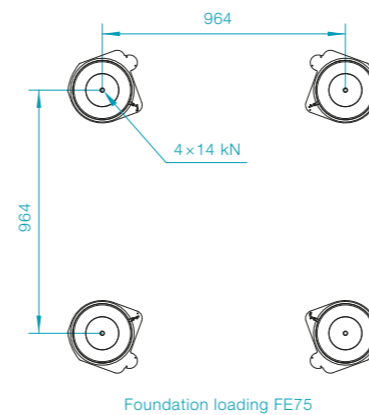

Explore More Products and Services

Complete brochure overview:
www.fette-compacting.com/en/downloads



Containment Guard

With the Containment Guard, Fette Compacting standardizes the retention performance of containment systems and makes it measurable and comparable in real-world conditions. On this basis, we integrate machines and processes for the safe handling of active ingredients from R&D to serial production.

- + Integrated, end-to-end containment
- + Measurable retention performance and SMEPAC validation
- + Custom-fit solution for your specific requirements



Brochure: Containment Guard

Together – from lab to production

With us, your product reaches market readiness faster. As an experienced R&D and process partner, Fette Compacting supports manufacturers with decades of expertise across the entire product lifecycle – from the first formulation concept to market launch and production.

- + Effective consulting and testing under GMP conditions
- + Services from formulation to process optimization
- + Faster time-to-market for your product



Brochure: Together – from lab to production

together 
from lab
to production

Tableting Tools

Our tableting tools optimize the performance and cost-efficiency of your tablet production. Precisely engineered punches and segment technologies, premium materials, and coatings increase output, reduce wear, and ensure consistently high tablet quality.

- + Higher output through optimized tool geometry
- + Longer service life and reduced wear
- + Efficient handling, cleaning, and tool management



Brochure: Tableting Tools

R&D Solutions

Our R&D Solutions guide you from the first powder analysis all the way to validated serial production. Based on the Quality by Design (QbD) principle and cutting-edge technology, we minimize scale-up risks and shorten your time-to-market – for robust, scalable, and reliable tableting processes.

- + Efficient formulation development
- + Production-like process development
- + Seamless scale-up and secure technology transfer
- + Global training program



Brochure: R&D Solutions



Production Services

Our Production Services provide comprehensive support for your tablet production – from initial commissioning to process optimization in day-to-day operation. Our experts ensure maximum machine availability, minimal downtimes, and future-proof systems.

- + Technical support and fast spare parts management
- + Data-driven process optimization and fleetmanagement
- + Machine modernization and refurbished pre-owned machines
- + Global training program



Brochure: Production Services

Global Training Program

With our global training program, we bridge the gap between theory and practice and help you unlock the full potential of your tableting processes. We offer tailored modules for every phase of your process – from development to maintenance.

- + Standard modules and customized training programs
- + Certification according to 21 CFR
- + Flexible delivery at your site or at our Competence Centers
- + Global training program in six languages



Brochure: Global Training Program



Europe

Fette Compacting GmbH

Grabauer Strasse 24
 21493 Schwarzenbek, Germany
 Phone +49 4151 12-0
tablet@fette-compacting.com

Fette Compacting Ibérica SL

Avenida Labradores, 1
 2ª Planta, Oficina 3
 28760 Tres Cantos, Spain
 Phone +34 91 8039689
fcib@fette-compacting.com

Fette Compacting France

10 Allée Bienvenue
 93160 Noisy-le-Grand, France
 Phone +33 155 812121
fcf@fette-compacting.com

Fette Compacting Italia Srl

Via Bruno Tosarelli, 155
 40055 Bologna, Italy
 Phone +39 340 5603976
fcit@fette-compacting.com

Fette Compacting Belgium BV

Schallenhoevedreef 1b
 2800 Mechelen, Belgium
 Phone +32 15 684260
fcbe@fette-compacting.com

EuroPharma Machinery Ltd

Unit 12 Highview
 Bordon, Hampshire, GU35 0AX
 United Kingdom
 Phone +44 1420 473344
admin@europharma.co.uk

Asia

Fette Compacting (China) Co., Ltd.

No. 9 Shengtong Road,
 Moling Sub-District,
 Jiangning Development Zone,
 211111 Nanjing
 Jiangsu Province, P.R.C., China
 Phone +86 25 52121818
fcn@fette-compacting.com

Fette Compacting Machinery India Private Limited

Plot No. S 115, Phase III B
 Verna Industrial Estate
 Verna, Goa 403 722, India
 Phone +91 90498 54568
marketing-in@fette-compacting.com

Fette Compacting Asia Pacific Pte Ltd.

2 Bukit Merah Central #18-01
 Singapore 159835, Singapore
 Phone +65 6371 1556
infoasiapacific@fette-compacting.com

Fette Compacting Middle East FZE

Jebel Ali Free Zone, Jafza
 Lobby 14, Office 308, Dubai
 United Arab Emirates
 Phone +971 4 8808226
dubai@fette-compacting.com

North America

Fette Compacting America, Inc.

400 Forge Way
 Rockaway, NJ 07866, USA
 Phone +1 973 5868722
sales@fetteamerica.com

Latin America

Fette Compacting America Latina Ltda.

Av. Cambacica, 610 módulo 10
 Parque Imperador
 CEP 13097-160
 Campinas / SP, Brazil
 Phone +55 19 37969910
fcsl-info@fette-compacting.com

Fette Compacting Mexico, SA de CV

Adolfo Prieto No. 1638
 Colonia Del Valle Sur
 03100 CDMX, Mexico
 Phone +52 55 40000653
tablet@fette-compacting.com

Africa

Fette Compacting North-West Africa

Résidence les Jardins, Bt B, Chéraga
 16000 Algiers, Algeria
 Phone +213 770 117 007
fcnwa@fette-compacting.com

© by Fette Compacting GmbH

This publication may not be reprinted in whole or part without our express permission. All rights reserved. No rights may be derived from any errors in content or from typographical or typesetting errors. Diagrams, features and dimensions represent the current status on the date of issue of this leaflet. We reserve the right to make technical changes. The visual appearance of the products may not necessarily correspond to the actual appearance in all cases or in every detail.

www.fette-compacting.com